



Masonry Division of Keene Building Products

MOISTURE MANAGEMENT FOR MASONRY

TotalFlash®

Product Submittal Sheet

Description

TotalFlash is a fully integrated flashing & drainage system, pre-assembled onto easily installed 5-1/2-foot (5-foot net) panels of flexible flashing. TotalFlash is suitable for use at all flashing locations, including base of wall, above exterior wall openings and bond beams, in parapet walls, and wherever flashing is desirable.

Each 5-1/2-foot panel includes a precisely defined 6-inch lap joint clearly marked to show where to place the adhesive beads and a built-in vertical edge dam for greater moisture protection. One panel is designed as a starter panel and is included in every box of TotalFlash along with 100 self-tapping #14 x 2" hex screws with self-sealing gaskets.

To complete the TotalFlash® Cavity Wall Drainage Solution, stainless steel, cold rolled copper or Kynar®-finish outside drip edge corners, 14" preformed inside and outside corner boots, universal end dams, and BTL-1 Butyl sealant may be ordered separately.

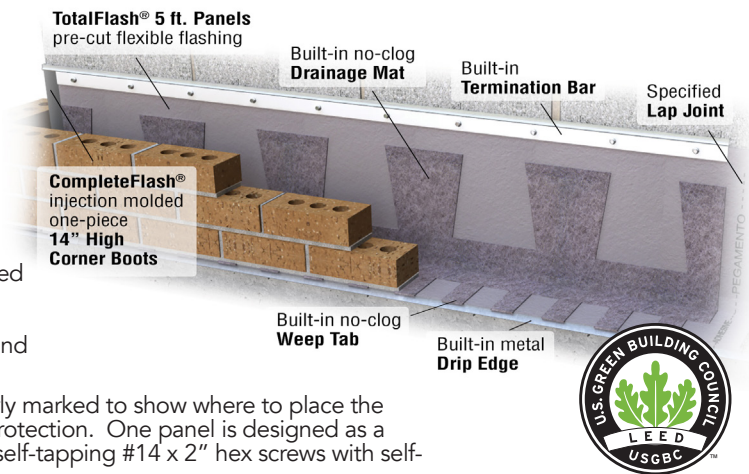

Short Form Spec

Install all-inclusive flashing/drainage system with adhered Cavity Drainage/Mortar Collection Material, Drip Edge, Termination Bar, Weep Tabs with included Fasteners. Replaces the requirements for Flashing, Weeps, Mortar Collection products, Drip Edge and Termination Bar.

Product: Subject to compliance with requirements, provide "TOTALFLASH® by Mortar Net Solutions™"

Manufacturer

Mortar Net Solutions™ - Masonry Division of Keene Building Products

6575 Daniel Burnham Drive, te G. Portage, IN 46368

Telephone: (800) 664-6638 Fax: (219) 787-5088

Email: info@mortarnet.com Website: www.mortarnet.com

Specifier Note: The TotalFlash® Cavity Wall Drainage Solution includes a 12", 18", or 24" 45-mil EPDM, 40-mil Rubberized Asphalt, 40-mil Thermoplastic Polyolefin (TPO), 3-mil Stainless Steel, or 5-ounce Copper Laminate membrane; recycled polyester 3/16" x 10" MortarNet® drainage mat; drip edge choices of 26-gauge 304 stainless steel, 24-gauge cold rolled copper, or 24-gauge Kynar®-finish galvanized steel; colors include Almond, Terra-Cotta, Gray and Tan (all options available separately in 5' lengths); high strength corrosion and UV resistant plastic termination bar or 16-gauge stainless steel termination bar is also available; and no-clog weep tabs. Self-tapping hex head screws are #14 x 2". 14" preformed inside and outside corner boots and universal end dams are made of high-performance membranes.

Substitutions: No substitutions permitted.

Panel Height

- 12"
- 18"
- 24"
- Custom

Membrane

- 45-Mil EPDM
- 40-Mil Rubberized Asphalt
- 40-Mil TPO
- Stainless Steel
- Self-Adhering Stainless Steel
- 5oz. Copper
- Other

Drip Edge

- 26-gauge Stainless Steel
- 24-gauge Kynar Galvanized Steel*
- 24-gauge Cold-rolled Copper
- No Drip Edge

*Kynar Galvanized Color Options

- Terra-cotta Gray
- Almond Tan

Termination Bar

- PVC
- 16-gauge Stainless Steel
- 16-gauge Stainless Steel w/Lip
- No Term Bar

Specification Title _____

Project _____

Firm _____ Phone _____

Approval _____ Date _____

General Contractor _____ Bid Date _____

Comments _____





Masonry Division of Keene Building Products

Metal Drip Edge Corners

Product Submittal Sheet

Description

Mortar Net Solutions offers metal drip edge corners that match the profile of our drip edge to help maintain the functionality of the flashing installation while creating a clean-looking corner every time.

Manufacturer

Mortar Net Solutions™ - Masonry Division of Keene Building Products

23750 St. Clair Avenue. Euclid, OH 44117

Telephone: (800) 664-6638 Fax: (219) 787-5088

Email: info@mortarnet.com

Website: www.mortarnet.com

Specifier Note: Mortar Net Solutions fixed 90° outside drip edge corners and adjustable drip edge corners are offered in 26-gauge stainless steel, 24-gauge Kynar-coated galvanized steel (multiple colors), and 24-gauge Copper.

Substitutions

No substitutions permitted.



Component (Check all that apply)

- 90° Fixed
- Adjustable 22° to 325°

Material

- 26-gauge Stainless Steel
- 24-gauge Kynar Galvanized Steel
- 24-gauge Copper

Specification Title _____

Project _____

Firm _____

Approval _____

Phone _____

Date _____

General Contractor _____

Bid Date _____

Comments





Masonry Division of Keene Building Products

MOISTURE MANAGEMENT FOR MASONRY

CompleteFlash™

Product Submittal Sheet

Description

CompleteFlash High Corner Boots & End Dams

Mortar Net Solutions™ offers durable Synthetic Rubber or Thermoplastic Polyolefin (TPO) 14" high inside/outside preformed corner boots specifically designed for masonry cavity walls. Unlike standard 8" corner boots, they extend above the typical flashing height, ensuring you can consistently achieve high-quality corners with ease.

Our one-piece preformed end dams are essential for ensuring leak-proof flashing installations and systems. They create a secure seal with flashing membranes, preventing water from leaking around lintel ends above windows, doors, and other wall openings, as well as at the termination points of flashing runs.

Synthetic Rubber is compatible with ethylene propylene diene terpolymer (EPDM), rubberized asphalt, thermoplastic polyolefin (TPO), copper (both cold rolled and fabric) and stainless-steel flashings currently on the market.

TPO is compatible with ethylene propylene diene terpolymer (EPDM), thermoplastic vinyl (PVC), thermoplastic polyolefin (TPO), copper (both cold rolled and fabric) and stainless-steel flashings currently on the market.



Manufacturer

Mortar Net Solutions™ - Masonry Division of Keene Building Products

23750 St. Clair Avenue. Euclid, OH 44117

Telephone: (800) 664-6638 Fax: (219) 787-5088

Email: info@mortarnet.com

Website: www.mortarnet.com

Specifier Note: CompleteFlash® pre-formed inside and outside corner boots and left, right and universal end dams are made of a synthetic rubber/polypropylene blend or Thermoplastic Polyolefin (TPO).

Substitutions

No substitutions permitted.

Materials

- Synthetic Rubber
- TPO

Components (Check all that apply)

- 14" High Outside Corner Boot
- 14" High Inside Corner Boot
- Universal End Dam
- Left End Dam
- Right Dam

Specification Title _____

Project _____

Firm _____

Approval _____

Phone _____

Date _____

General Contractor _____

Bid Date _____

Comments



KBP_962751_071824



Masonry Division of Keene Building Products

MOISTURE MANAGEMENT FOR MASONRY

Stainless Steel Corners & End Dams

Product Submittal Sheet

Description

Mortar Net Solutions' stainless steel inside & outside corners, and universal end dams help protect from moisture penetration at corners and end of runs in flashing installations. They are manufactured from 26-gauge Type 304 stainless steel for excellent durability and are soldered at joints to ensure leak-proof seams.

Install these flashing accessories under the flashing membrane being used. Their 26-gauge profile will allow for a smoother transition as opposed to field fabricated corners and end dams made from 40 or 60 mil flashing materials.

Type 304 stainless steel - ASTM A 240, ASTM A 666, ASTM A 480, ASTM A 167

Manufacturer

Mortar Net Solutions™ - Masonry Division of Keene Building Products

23750 St. Clair Avenue. Euclid, OH 44117

Telephone: (800) 664-6638 Fax: (219) 787-5088

Email: info@mortarnet.com

Website: www.mortarnet.com

Substitutions

No substitutions permitted.

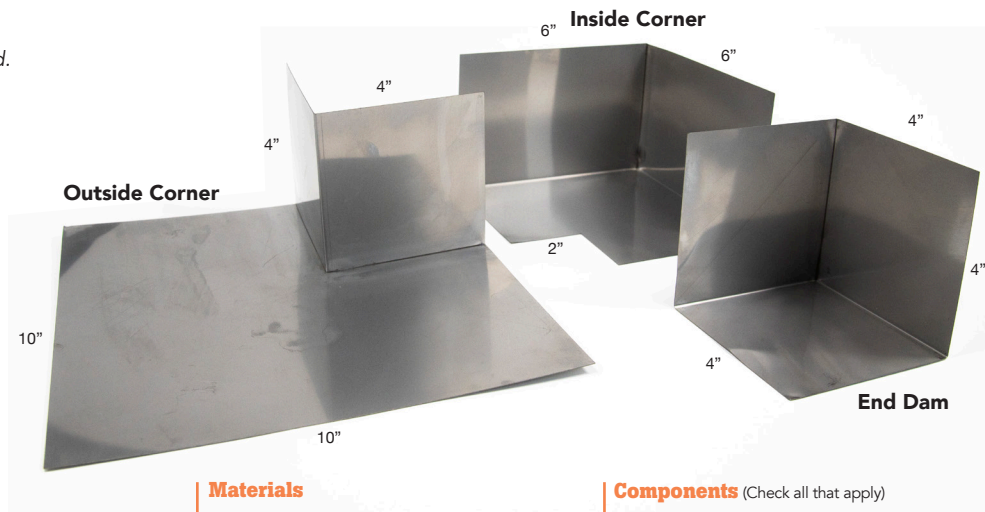

Materials

- Type 304 Stainless Steel

Components (Check all that apply)

- End Dam
- Inside Corner Boot
- Outside Corner Boot

Specification Title _____

Project _____

Firm _____

Approval _____

General Contractor _____

Phone _____

Date _____

Bid Date _____

Comments



KBP_713846_080724



Masonry Division of Keene Building Products

MOISTURE MANAGEMENT FOR MASONRY

BTL-1™ Butyl Sealant

Product Submittal Sheet

Description

BTL-1™ Sealant is a multi-purpose sealant to be applied by traditional means and is easily gunable and tooled. It is a moisture-curing sealant developed for industrial & commercial uses requiring elasticity, high strength and excellent adhesion.

Short Form Spec

Subject to compliance with requirements, provide BTL-1™ Sealant by Mortar Net Solutions™. BTL-1™ Sealant should be used only by experienced masons, water proofers or general contractors.

Manufacturer

Mortar Net Solutions™ - Masonry Division of Keene Building Products

6575 Daniel Burnham Drive Suite G, Portage, Indiana 46368

Telephone: (800) 664-6638

Fax: (219) 787-5088

Email: info@mortarnet.com

Website: www.mortarnet.com

Substitutions

No substitutions permitted.



Component (Check all that apply)

- BTL-1 Adhesive and Sealant: 1 - 10.3 oz. cartridge

Specification Title _____

Project _____

Firm _____

Phone _____

Approval _____

Date _____

General Contractor _____

Bid Date _____

Comments



KBP_291684_081324



Masonry Division of
Keene Building Products

MOISTURE MANAGEMENT FOR MASONRY

TotalFlash[®]

The patented TotalFlash Cavity Wall Drainage Solution is an all-in-one, factory-assembled masonry cavity wall flashing system designed to reduce labor costs and enhance performance compared to standard through-wall flashing.

The system is versatile and suitable for all flashing locations, including the base of walls, above exterior wall openings, bond beams, parapet walls, and any other areas where flashing is needed.

Features

- **Includes:** Flashing membrane assembled with a no-clog mortar-dropping collection drainage mat, weep tabs, drip edge, termination bar with pre-drilled holes, and fasteners into a single easy-to-install panel
- **Customization:** Built to the specification of the job using virtually any flashing membrane on the market
- **Repetitive openings:** Pre-assembled, custom-sized panels designed specifically for the opening's conditions.
- **Water-tight:** Proven overlap and termination method quickly and easily creates air- and water-tight lap joints and terminations
- **Additional components:** CompleteFlash™ 14" inside/outside preformed High Corner Boots and end dams, preformed metal 90° outside drip edge corners or adjustable drip edge corners, and BTL-1 sealant are sold separately

Benefits

- **Time savings:** Cuts installation time by at least 50% compared to field-installed through-wall flashing pieces and parts
- **Mortar collection device:** Not required with TotalFlash system
- **Restoration:** Ideal for restoration projects with a variety of standard and custom sizes
- **Support:** TotalFlash is more than just a product. Every awarded TotalFlash job includes expert takeoff and assistance to ensure a smooth purchasing and installation process.

Sizes & Packaging

- **Standard panel height:** 12", 18", or 24"
- **Standard panel length:** 5-1/2' (5' net)
- **Panels/Box:** 10
- **Starter panel:** 1/box for left-to-right installation



Masonry Cavity Wall Drainage Solution

It's Much More Than Just Flashing



Select a flashing membrane, termination bar, and drip edge. Mortar Net factory assembles all of the components and ships to you ready-to-install right out of the box.



Complete the system with BTL-1 butyl sealant, metal corner drip edge, and CompleteFlash corner boots & end dams.



Request technical or takeoff assistance

Steven Fecino

Engineering & Construction Mgr.

(219) 850-4514

sfechino@mortarnet.com





Masonry Division of
Keene Building Products

MOISTURE MANAGEMENT FOR MASONRY

Select your Panel Options Below

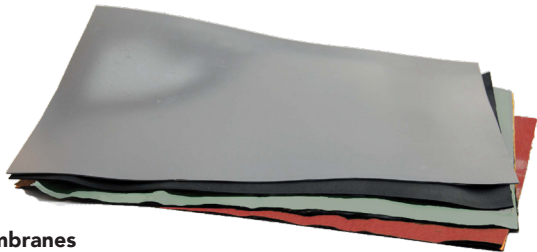

Flashing Membranes

- **EPDM:** 45-Mil synthetic rubber offering superior flexibility and durability during cold-weather installations
- **Rubberized Asphalt:** 0.032" rubberized asphalt bonded to 0.008" polyethylene film, self-adhering, excellent tensile/elongation/permanence characteristics, temperature resistant to 245° F
- **Thermoplastic Polyolefin (TPO):** 40-Mil, UV stable
- **Stainless Steel:** 0.003" single sheet of 304 stainless steel bonded on one side to a layer of polymeric fabric offering superior tensile strength, fire resistant, UV Stable
- **Copper Laminate:** 5 oz. Copper sheet reinforced with 2 layers of polypropylene fabric
- **Other:** TotalFlash system can be built with most flashing membranes on the market



Termination Bars

- **PVC:** 1 1/4" high x 1/8" thick, UV stabilized, non-migratory plasticizers, high strength, corrosion resistant, pre-drilled holes
- **Stainless Steel:** 1" x 16-gauge thick, Flat or Lip, Type 304 2B, pre-drilled holes 8" on-center, 100% recyclable
- **Aluminum:** Available upon request



Drip Edges

- **Stainless Steel:** 3" x 26-gauge, 3/8" hemmed edge
- **Cold-rolled Copper:** 3" x 24-gauge, 3/8" hemmed edge
- **Kynar®-coated galvanized steel:** 3" x 24-gauge, 3/8" hemmed edge, 4 color choices (Almond, Tan, Gray, Terracotta)

Complete the System (components sold separately)



CompleteFlash™ Corner Boots & End Dams

- TPO, or synthetic rubber/polypropylene blend:
- 14" High inside/outside Corner Boots
- End Dams: right, left, universal



Metal Drip Edge Corners

- Available in 26-gauge Stainless Steel, 24-gauge Kynar-coated, or 24-gauge Copper
- Pre-formed outside 90°
- Adjustable 325° to 22°



Sealant: BTL-1 Butyl

- Permanently elastic and tacky
- Freeze thaw stable
- Single-component, moisture cure



2024 TotalFlash Sell Sheet_KBP_641587_080924

Notes:

- The use of Carborundum Saw blades to cut the Stainless Steel Drip Edge can result in a slight surface rust on any exposed metal.
- Muriatic Acid at any dilution is not recommended on Stainless Steel. • Uses a 5/32" Drill Bit & 5/16" Nut Driver
- Instructions for removing drip edge: When long runs of TotalFlash do not require the starter panel, the lap can be created by cutting with a knife the glue that holds the drip edge to the membrane and snipping off 6 inches of drip edge.

1 STEP ONE

Apply sealant / adhesive to prefabricated Stainless Steel Corner **A** using 1 bead of adhesive.

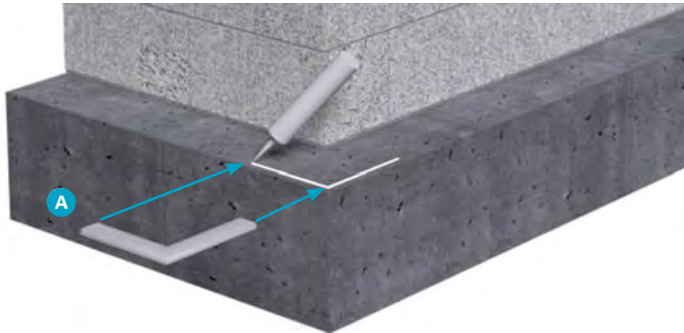

2 STEP TWO

Install pre-formed 14" Corner Boot **B** using 1 bead of sealant / adhesive.

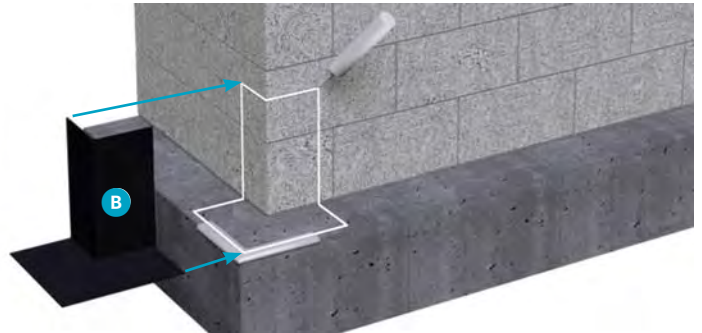

3 STEP THREE

Begin TotalFlash installation at the leftmost corner using the TotalFlash starter strip.

Install starter strip **C** adjacent to corner drip using sealant / adhesive applied horizontally behind termination bar and drip edge and two beads vertically at ends of TotalFlash panel as shown to the right. Install subsequent sections of TotalFlash from left to right.

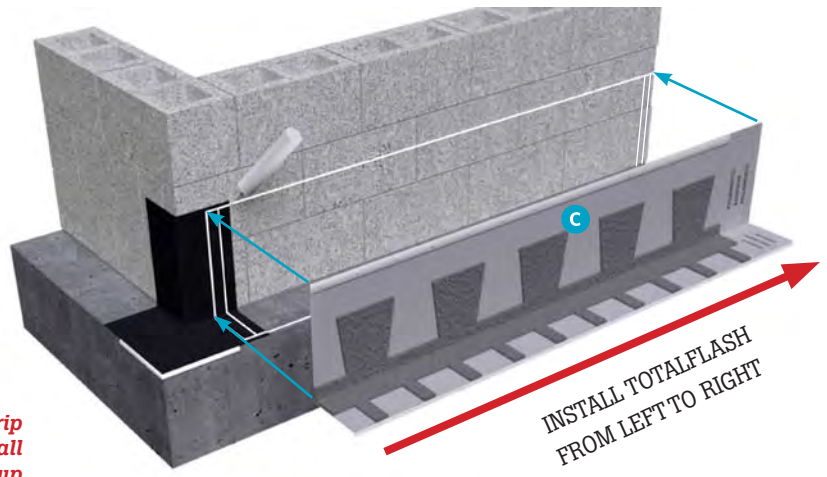

Sealant / Adhesive sets up quickly:

Install the Drip Edge on brick ledge. Create the crease at Drip Edge & backup wall until tight. Work the TotalFlash up the wall creating a smooth tight fit. Attach Termination Bar to the backup wall. Termination Bars may not align horizontally.

4 STEP FOUR

Install remaining sections using the lap system and sealant / adhesive. Caulk top of termination bar **D**. Loose brick units can be used to temporarily hold down TotalFlash while sealant / adhesive cures.

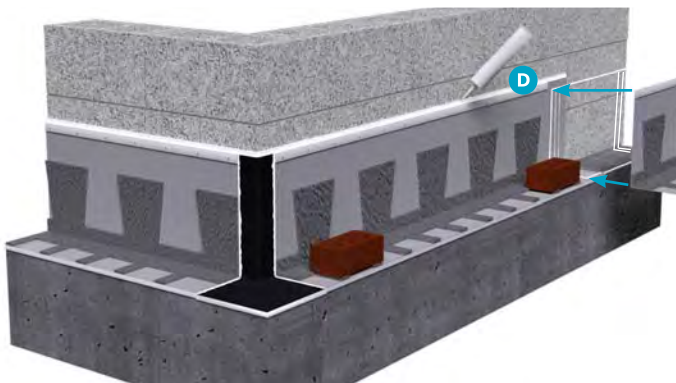

5 STEP FIVE

Install remaining rigid board insulation over TotalFlash. Lay a mortar bed directly atop the TotalFlash weep tabs and install the brick veneer. For proper drainage, ensure the tips of the weep tabs are exposed when tooling the first mortar joint.

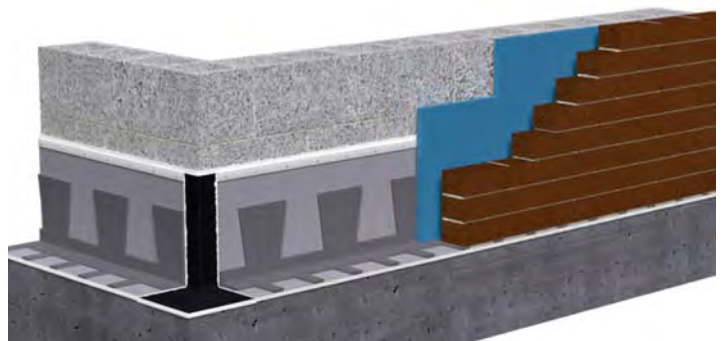

Notes:

- The use of Carborundum Saw blades to cut the Stainless Steel Drip Edge can result in a slight surface rust on any exposed metal.
- Muriatic Acid at any dilution is not recommended on Stainless Steel. • Uses a 5/32" Drill Bit & 5/16" Nut Driver
- Instructions for removing drip edge: When long runs of TotalFlash do not require the starter panel, the lap can be created by cutting with a knife the glue that holds the drip edge to the membrane and snipping off 6 inches of drip edge.

1 STEP ONE

Apply sealant / adhesive to prefabricated Stainless Steel Corner **A** using 1 bead of adhesive.

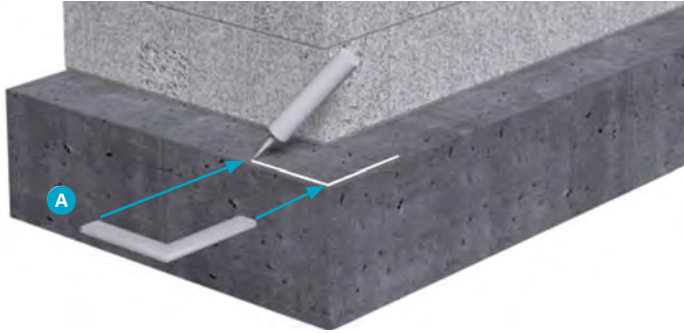

2 STEP TWO

Install pre-formed 14" Corner Boot **B** using 1 bead of sealant / adhesive.

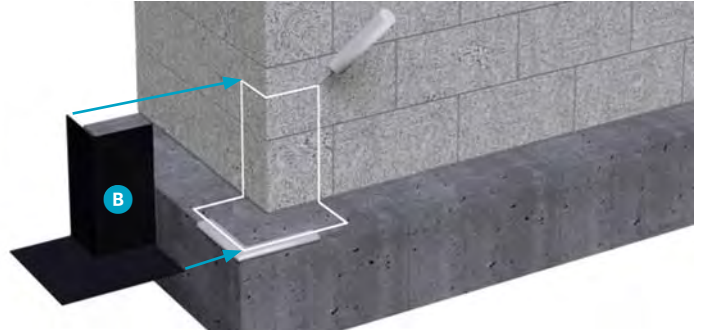

3 STEP THREE

Install 8" high sections of rigid insulation board against back up wall.

Begin TotalFlash installation at the leftmost corner using the TotalFlash starter strip **C** adjacent to corner drip using sealant / adhesive applied horizontally behind termination bar and drip edge and two beads vertically at ends of TotalFlash panel as shown to the right. Install subsequent sections of TotalFlash from left to right.

Sealant / Adhesive sets up quickly:
Install the Drip Edge on brick ledge. Create the crease at Drip Edge & backup wall until tight. Work the TotalFlash up the wall creating a smooth tight fit. Attach Termination Bar to the backup wall. Termination Bars may not align horizontally.

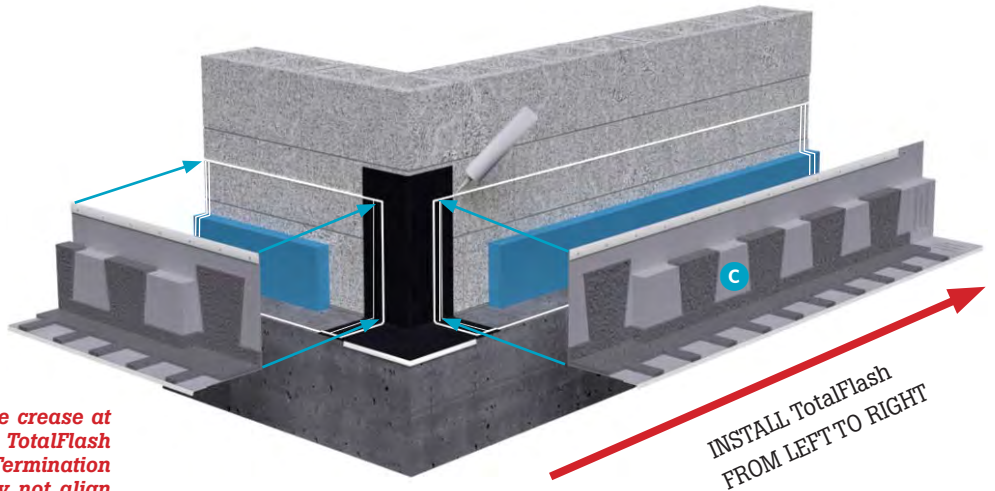

4 STEP FOUR

Install remaining sections using the lap system & adhesive, trim end section flush with corner drip. Caulk top of termination bar **D**. Use loose bricks to temporarily hold down TotalFlash while sealant / adhesive cures.

Caulk top of Corner Boot

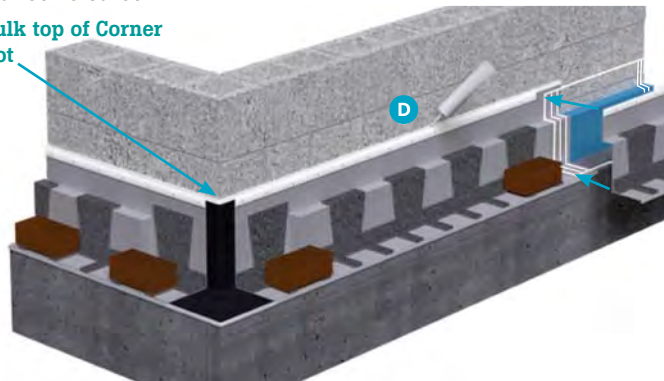

5 STEP FIVE

Install remaining rigid insulation board.

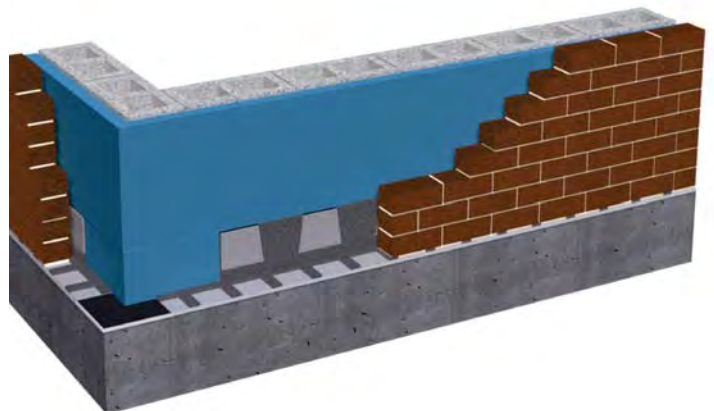

Notes:

- The use of Carborundum Saw blades to cut the Stainless Steel Drip Edge can result in a slight surface rust on any exposed metal.
- Muriatic Acid at any dilution is not recommended on Stainless Steel. • Uses a 5/32" Drill Bit & 5/16" Nut Driver
- Instructions for removing drip edge: When long runs of TotalFlash do not require the starter panel, the lap can be created by cutting with a knife the glue that holds the drip edge to the membrane and snipping off 6 inches of drip edge.

1 STEP ONE

Install pre-formed 14" Corner Boot **A** using 1 bead of sealant / adhesive.

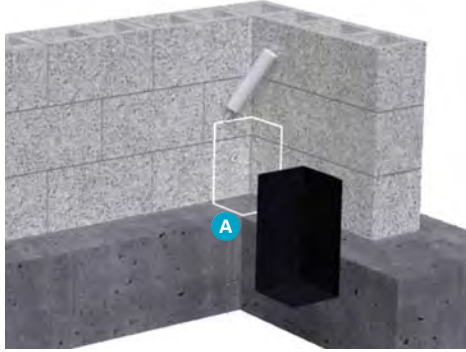

2 STEP TWO

Install 8" high sections of rigid insulation board against backup wall 12" from corner.



3 STEP THREE

Begin TotalFlash installation at the leftmost edge of the wall using the TotalFlash starter strip piece **B** (place it directly against the stainless steel corner piece previously set). Use sealant / adhesive applied horizontally behind termination bar and drip edge and two beads vertically at ends of TotalFlash panel as shown to the right. Trim off excess TotalFlash panel. **C**.

Install remaining sections using the lap system and sealant / adhesive. Caulk top of termination bar

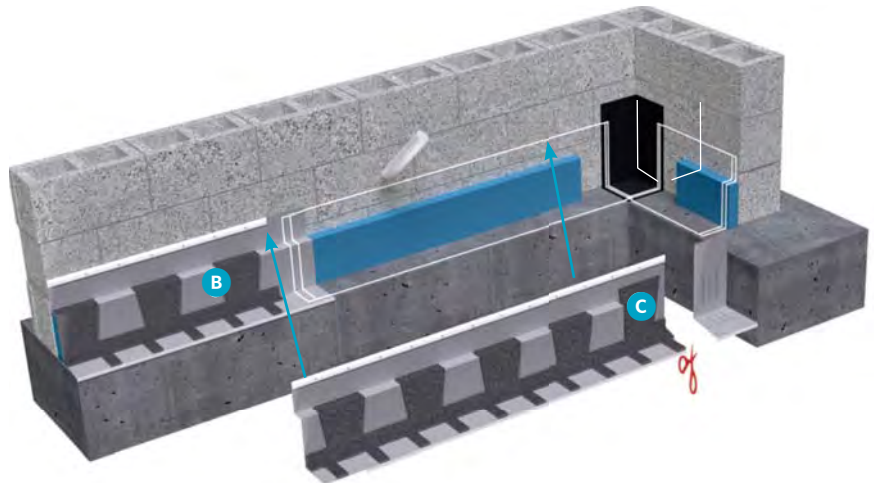

4 STEP FOUR

Trim the left side of the TotalFlash drip edge hem at 45° and install into inside corner with sealant / adhesive and termination bars screws supplied.

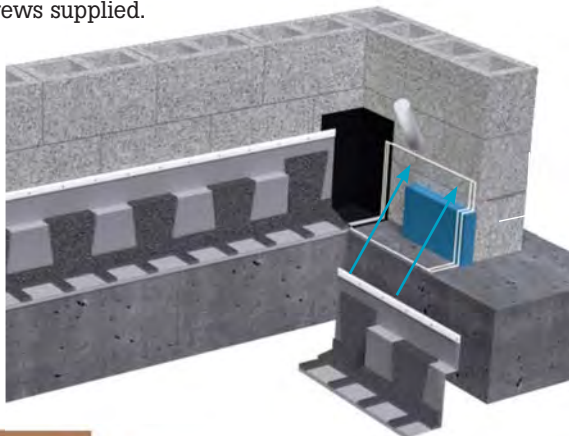

5 STEP FIVE

Trim top of Corner Boot flush with Termination Bar. Caulk top of termination bar **D**. Loose brick units can be used to temporarily hold down TotalFlash while sealant / adhesive cures.



Notes:

- The use of Carborundum Saw blades to cut the Stainless Steel Drip Edge can result in a slight surface rust on any exposed metal.
- Muriatic Acid at any dilution is not recommended on Stainless Steel. • Uses a 5/32" Drill Bit & 5/16" Nut Driver
- Instructions for removing drip edge: When long runs of TotalFlash do not require the starter panel, the lap can be created by cutting with a knife the glue that holds the drip edge to the membrane and snipping off 6 inches of drip edge.

1

STEP ONE

Install pre-formed end dams **A** on both ends of opening using sealant / adhesive, trim to fit.

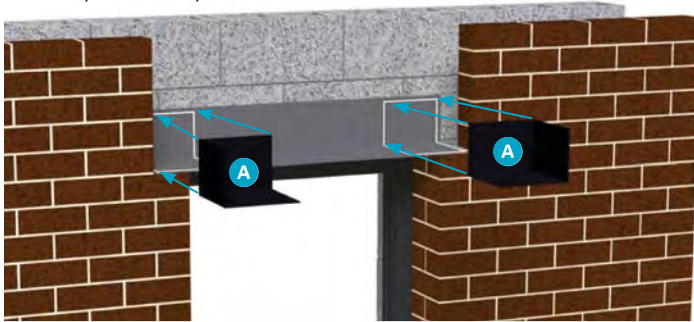

2

STEP TWO

Install 8" high sections of rigid insulation board against back up wall at lintel.

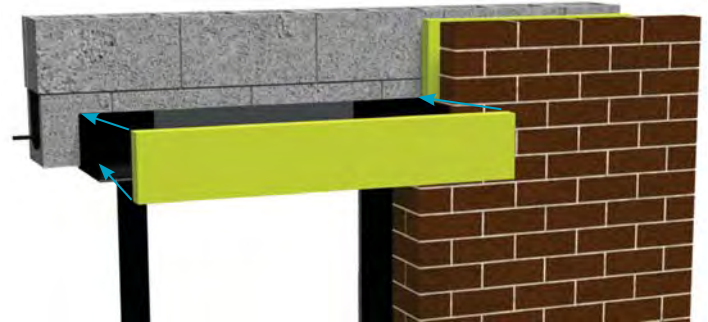

3

STEP THREE

Install first section of TotalFlash adjacent to end dam using sealant / adhesive and screws. Trim TotalFlash to fit opening.

For larger openings, install additional TotalFlash sections using the integrated lap system, sealant / adhesive and screws.



4

STEP FOUR

Caulk top of Termination Bar.



5

STEP FIVE

Install remaining rigid insulation board and install brick veneer.



BEFORE PROCEEDING: If you have questions or need more information, please contact Mortar Net Solutions® at **800-664-6638** or go to **www.mortarnet.com**

Notes:

• The use of Carborundum Saw blades to cut the Stainless Steel Drip Edge can result in a slight surface rust on any exposed metal.

• Muriatic Acid at any dilution is not recommended on Stainless Steel.

• Uses a 5/32" Drill Bit & 5/16" Nut Driver

• Instructions for removing drip edge: When long runs of TotalFlash do not require the starter panel, the lap can be created by cutting with a knife the glue that holds the drip edge to the membrane and snipping off 6 inches of drip edge.

1 STEP

Install pre-formed end dams **A** on both ends of opening using sealant / adhesive, trim to fit.

2 STEP TWO

Install first section of TotalFlash adjacent to end dam using sealant / adhesive and screws. Trim TotalFlash to fit opening.

For larger openings, install additional TotalFlash sections using the integrated lap system, sealant / adhesive and screws.

3 STEP THREE

Caulk top of Termination Bar **B**. Install rigid insulation on top of TotalFlash. Install brick veneer above lintel.

INSTALLATION GUIDE B Window Head Flashing TotalFlash Installed in Front of Rigid Insulation Board

For even faster installation contact Mortar Net Solutions® to inquire about TotalFlash window head panels made to the exact size needed.

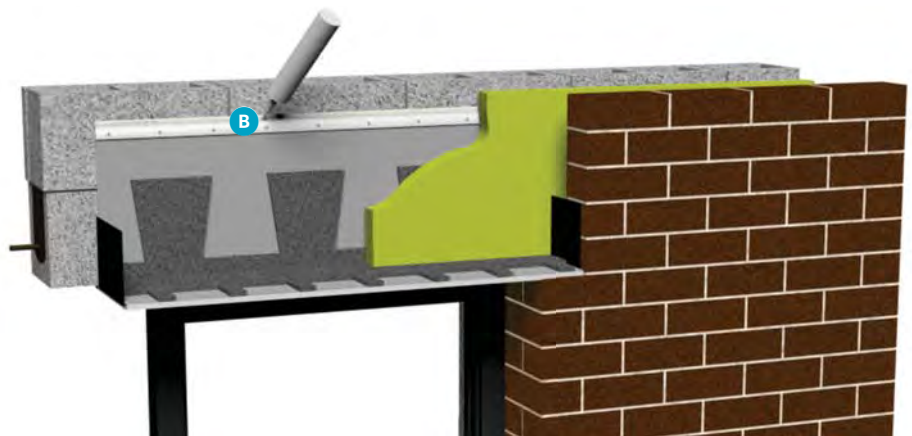
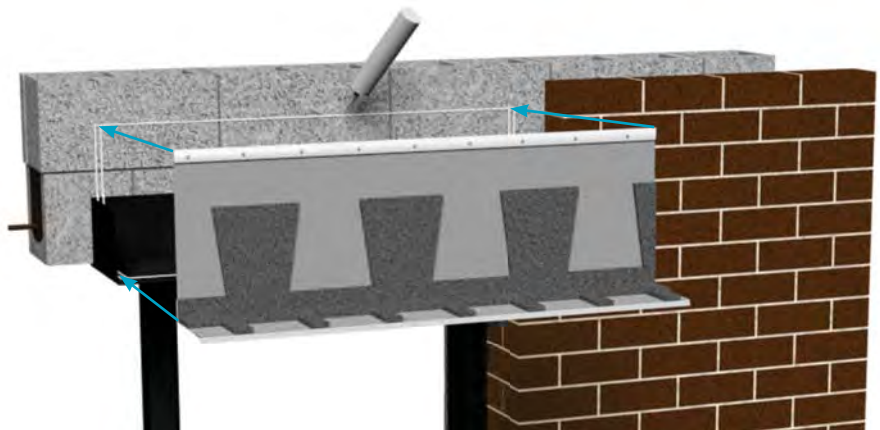
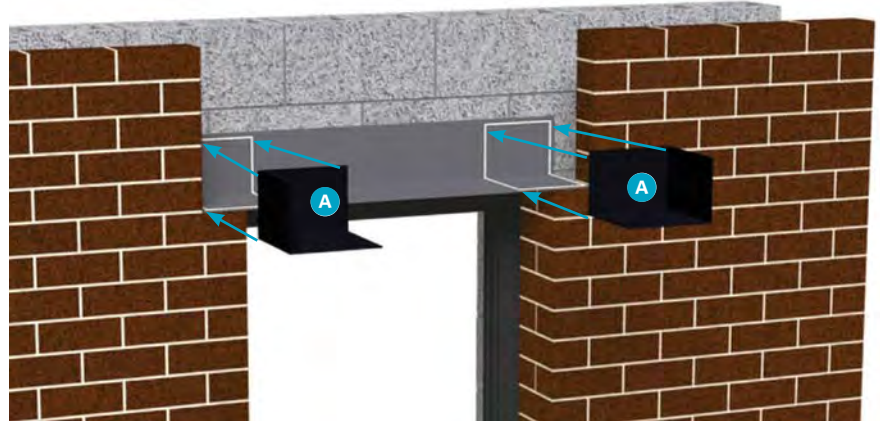

BEFORE PROCEEDING: If you have questions or need more information, please contact Mortar Net Solutions® at **800-664-6638** or go to www.mortarnet.com



Moisture
Management
for Masonry

326 Melton Rd., Burns Harbor, IN 46304
P 800 664 6638 F 219 787 5088
www.mortarnet.com

Certificate of Compliance

This letter is to certify that TotalFlash® meets specifications as described.

TotalFlash® was tested in accordance with ASTM E514, "Test Method for Water Penetration and Leakage Through Masonry".

TotalFlash® is manufactured in the United States and meets the requirements as described in the American Recovery and Reinvestment Act (ARRA) of 2009.

Regards,

A handwritten signature in black ink, appearing to read "Greg Skyta", is written over a light gray circular stamp.

Greg Skyta
Construction Services
Business Development Associate
gskyta@mortarnet.com
219-850-4516



Moisture
Management
for Masonry

326 Melton Rd., Burns Harbor, IN
P 800 664 6638 F 219 787 501
www.mortarnet.com

TotalFlash®

Testing

TotalFlash®

1/9

NELSON TESTING LABORATORIES

Construction Materials

1210 REMINGTON ROAD

SCHAUMBURG, ILLINOIS 60173 USA

Phone (847) 882-1146 Fax (847) 882-1148

www.nelsontesting.com

December 5, 2007

Mortar Net Solutions®
326 Melton Road
Burns Harbor, IN 46304

REPORT OF TESTS

SUBJECT: Water Penetration Study to Determine the Effectiveness of the Mortar Net TotalFlash Cavity-Wall Drainage System Used in Masonry Cavity Wall Construction

PROJECT: Mortar Net Solutions® Research Program - TotalFlash®

TEST METHODS: ASTM E 514, "Test Method for Water Penetration and Leakage Through Masonry"

ASTM C 67, "Test Methods of Sampling and Testing Brick and Structural Clay Tile"

ASTM C 140, "Standard Test Methods for Sampling and Testing Concrete Masonry Units and Related Units"

ASTM C 270, "Specification for Mortar for Unit Masonry"

NTL PROJECT #: 1039-07

PAGE: 1 of 9

TEST OVERVIEW

This study was designed to test the effectiveness of Mortar Net's TotalFlash cavity-wall drainage system in masonry cavity wall construction. Within this study, three masonry cavity walls were constructed and subjected to the test procedures outlined in ASTM E 514, "Test Method for Water Penetration and Leakage Through Masonry". The walls were constructed each with a first course of brick and a second course of concrete masonry units. Two wall systems were constructed with the TotalFlash cavity-wall drainage system installed at the base of the second course of concrete masonry units, while the third wall was constructed with no water management system, except for standard peel and stick flashing. All three walls were constructed with the intent to allow leakage through the brick to test the effectiveness of the TotalFlash cavity-wall drainage system.

December 5, 2007
Mortar Net Solutions®
TotalFlash Cavity-Wall Drainage System
NTL Project #1039-07
Page 2 of 9

TEST WALL DESCRIPTIONS

Wall #1 – TotalFlash #1

- Brick facing wythe;
- TotalFlash cavity-wall drainage system installed within a 1" cavity;
- Concrete masonry unit wythe.

Wall #2 – TotalFlash #2

- Brick facing wythe;
- TotalFlash cavity-wall drainage system installed within a 1" cavity;
- Concrete masonry unit wythe.

Wall #3 – Control #1

- Brick facing wythe;
- Peel and stick flashing installed within a 1" cavity;
- Concrete masonry unit wythe.

December 5, 2007
Mortar Net Solutions®
TotalFlash Cavity-Wall Drainage System
NTL Project #1039-07
Page 3 of 9

TEST WALL FABRICATION

Three (3) walls for water penetration testing were constructed according to ASTM E 514 requirements. The three walls were double-wythe wall panels, 48" wide x 56" high. Each wall was assembled using a face of clay brick and a second of concrete masonry units (cmu). A one-inch air cavity was located between the clay brick and the concrete masonry units. Each open end of the walls used a water end dam. In the first two walls, the mason installed the Mortar Net TotalFlash product in the 1" cavity according the manufacturer recommendations. In the third wall, the mason installed peel and stick flashing in the 1" cavity.

The walls were built during a two day period by an experienced lead mason. Workmanship was judged as to be average. Ambient temperature was maintained between 60 degrees F. and 75 degrees F. during the fabrication and subsequent curing period. Each wall was constructed by one mason and required approximately 1.5 hours to complete with the masonry work being done over a period of about 60 minutes. The walls were constructed on an inverted steel channel, and the bottom course was laid on a bed of mortar. Full bedded mortar joints were used, and the walls were constructed one course at a time by applying mortar the full length of the bed joint, then buttering the ends of a brick one at a time before setting on the bed joint. The joints were initially struck and tooled with a concave jointer after the top course was laid, and a final tooling was done approximately 30 to 60 minutes later. The bed and head joints were full.

The walls were constructed in a random order to avoid potential systematic errors which might have occurred if the walls had been built in a particular order. The walls were cured according to ASTM E 514 which requires curing for 7 days enclosed in plastic sheeting and for a minimum of 7 subsequent days curing in laboratory air. The total curing time for the walls ranged from 14 to 21 days. Flashing was built into the wall to collect water that had passed completely through the wall. There was a bottom trough which was built under the wall to collect water that penetrated into the interior cavities on the blocks, collected at the bottom of the cavities and leaked through the weep holes and mortar joints.

TEST PROCEDURES

ASTM E 514 test procedures were followed throughout the test. ASTM E 514 test chambers were constructed of welded aluminum angle stock, and the observation face of the chambers was outfitted with Lexan sheet to allow full view into the chamber. All fixtures and appurtenances were in conformity with ASTM E 514, section 4. Each frame was outfitted with a monometer to measure interior pressure and a flow meter to monitor the amount of flow. During the testing, the frame was pressurized to 10 psf, and the water flow was adjusted to 40.8 gal/hour which is equal to 3.4 gal/sq.ft./hr. The units were held in place with clamps, and closed cell foam gasket materials.

December 5, 2007
 Mortar Net Solutions®
 TotalFlash Cavity-Wall Drainage System
 NTL Project #1039-07
 Page 4 of 9

MATERIAL TEST DATA

A. Concrete Masonry Units

Nominal 8" x 8" x 16", two core, medium weight concrete masonry units (CMU) were manufactured by Northfield Block Company, Mundelein, Illinois. The following are the CMU physical properties. The results represent the average of three units tested in conformity with ASTM C 140.

Compressive Strength, net, psi	2970
Dimensions	
Length, in.	15.65
Height, in.	7.65
Width, in.	8.00
Thickness	
Face shell, minimum in.	1.33
Web, minimum in.	1.25
Absorption	
Pcf	6.45
Percent	4.78
Moisture Content, percent	11.2
Unit weight, dry, pcf	114.3

Brick Analysis (ASTM C 67)

Brick size: 7.62 inches long x 3.62 inches wide x 2.25 inches high. The following are the clay brick physical properties. The results represent the average of three units tested in conformity with ASTM C67.

Absorption (%)	
24 hour	8.8
5 hour boil	10.3
Saturation Coefficient	0.83
IRA (g/min/30 sq.in.)	16.2
Compressive Strength (psi)	10,170

December 5, 2007
Mortar Net Solutions®
TotalFlash Cavity-Wall Drainage System
NTL Project #1039-07
Page 5 of 9

B. Mortar Batches

a. Mortar Batching Information

Similar Mix designs were utilized for each mortar batch. Mortar constituents were weigh-batched to assure accuracy. ASTM C 270, Type "S" mortar proportions were selected for the evaluation. The amount of water was adjusted to provide the required consistency as judged by the mason.

Mortar proportions are as follows:

Cement, Type 1	1 part
Lime	½ part
Mason Sand	4 ½ parts

b. Mortar Cementitious Materials

Cement	Portland Cement Type 1 (ASTM C 150)
Lime	Type "S" Hydrated Lime (ASTM C 207)

c. Mortar Aggregates – Mason Sand

Gradation	% Passing Each Sieve
# 4	100.0
# 8	100.0
# 16	90.4
# 30	78.3
# 50	28.9
# 100	2.0

F.M. 1.94

The mason sand meets ASTM C 144 specifications

d. Mortar Physical Properties

All mortar properties were obtained in accordance with ASTM C 780. Air contents were determined using the pressure method (ASTM C231). Compressive strengths were determined on 3-inch diameter by 6-inch high cylinders (ASTM C 39).

Plastic Mortar	
Cone penetration, mm	50
Air content, %	5.3
Hardened Mortar	
Compressive strength, PSI	
7 days	2480
28 days	2970

December 5, 2007
Mortar Net Solutions®
TotalFlash Cavity-Wall Drainage System
NTL Project #1039-07
Page 6 of 9

TEST RESULTS

A. OBSERVATIONS

Wall #1 – TotalFlash #1

No signs of dampness were visible on the back wall after the four-hour test. Also, no water was collected through the back of the wall. Measurable water began flowing through the weep holes 10 minutes after the start of the test. During the course of the four-hour test a total of 15 gallons of water exited through the weep holes. At the completion of the test, no water was found to have collected within the wall cavity.

Wall #2 – TotalFlash #2

No signs of dampness were visible on the back wall after the four-hour test. Also, no water was collected through the back of the wall. Measurable water began flowing through the weep holes 15 minutes after the start of the test. During the course of the four-hour test a total of 14.5 gallons of water exited through the weep holes. At the completion of the test, no water was found to have collected within the wall cavity.

Wall #3 – Control #1

Measurable water began trickling through the weep holes 90 minutes after the start of the test. During the course of the four-hour test a total 0.25 gallons of water exited the weep holes. At the completion of the test, water collected within the cavity to a height of 4.0 inches.

December 5, 2007
Mortar Net Solutions®
TotalFlash Cavity-Wall Drainage System
NTL Project #1039-07
Page 7 of 9

TEST RESULTS (continued)

B. DATA

ASTM E 514 Testing

Test Date:	11-13-07	11-14-07	11-14-07
	<u>TotalFlash Wall - 1</u>	<u>TotalFlash Wall - 2</u>	<u>Control Wall - 3</u>
First dampness on back of wall	no signs	no signs	180 minutes
First visible water on back of wall	no water	no water	no water
Percent dampness on back of wall @ 4 hours	0%	0%	10%
Total leakage through back of wall (gallons)	none	none	none
Total leakage rate through back of wall (gallons/hour)	0.00	0.00	0.00

December 5, 2007
Mortar Net Solutions®
TotalFlash Cavity-Wall Drainage System
NTL Project #1039-07
Page 8 of 9

TEST RESULTS (continued)

C. COMPARATIVE DATA

Water Collection Comparative Study

	<u>Water Collected Through Weep Holes</u>	<u>First Sign of Water Exiting Weep Holes</u>	<u>Depth of Water Remaining in Cavity Wall</u>
<u>Wall #1</u> – TotalFlash #1	15.0 gallons	10 minutes	no water
<u>Wall #2</u> – TotalFlash #2	14.5 gallons	15 minutes	no water
<u>Wall #3</u> – Control #1	0.25 gallons	90 minutes	4.00 inches
 <u>Average</u>			
TotalFlash	14.75 gallons	12.5 minutes	no water
Control	0.25 gallons	90 minutes	4.00 inches

December 5, 2007
Mortar Net Solutions®
TotalFlash Cavity-Wall Drainage System
NTL Project #1039-07
Page 9 of 9

TEST RESULTS (continued)

D. SUMMARY

The Mortar Net TotalFlash cavity-wall drainage system test walls showed no signs of dampness or water penetration through the back of the concrete masonry units at the conclusion of the ASTM E 514 tests. In addition, Mortar Net TotalFlash strongly outperformed the standard peel and stick flashing system during the course of this test procedure. While the wall cavities and the corresponding weep holes in the control wall became almost completely blocked with mortar droppings, the TotalFlash water management system provided a system for preventing mortar blockage, allowing water to escape through the weep holes.

Respectfully submitted,

NELSON TESTING LABORATORIES



Mark R. Nelson
Principal